

Set Portofino



Istruzioni di montaggio
Instructions d'assemblage
Assembling instructions
Aufbau Anweisungen
Instrucciones de montaje
Instruções de montagem

**IMPORTANTE, LEGGERE CON
ATTENZIONE E CONSERVARE PER
RIFERIMENTO FUTURO**

IMPORTANT, READ CAREFULLY AND
KEEP FOR FUTURE REFERENCE

**IMPORTANT, À LIRE
ATTENTIVEMENT ET À CONSERVER
POUR REFERENCE ULTERIEURE**

WICHTIG, SORGFÄLTIG LESEN UND
AUFBEWAHREN

**IMPORTANTE, LEA ATENTAMENTE
Y CONSERVELO PARA FUTURAS
CONSULTAS**

IMPORTANTE, LEIA COM ATENÇÃO
E GARDE PARA REFERÊNCIA
FUTURA



IS772701
Rev. 2



www.grandsoleilspa.it

**1 Divano +
2 Poltrone +
1 Tavolino**



Istruzioni
smaltimento
ambientale degli
imballaggi

I Prodotto Polipropilene fiberglass trattato anti UV
NON ESPORRE a + 50°C e - 0°
Usare su una superficie piana.
Pulire con acqua e sapone, **NON USARE SOLVENTI**

ARTICOLO AD USO DOMESTICO E COLLETTIVITÀ
Prodotto, testato e certificato a Norma Europea EN-581

F Produit en polypropylène fibre de verre avec traitement anti UV
NE PAS EXPOSER à + 50°C et à - 0°C
A utiliser sur un support plan.
Nettoyer avec eau et savon, **NE PAS UTILISER DE SOLVANTS**

ARTICLE À USAGE DOMESTIQUE ET COLLECTIVITÉ
Produit, testé et certifié aux Normes Européennes EN-581

GB Polypropylene fiberglass with anti-UV treatment product
DO NOT EXPOSE to + 50°C and - 0°
Use on a level surface.
Clean using soap and water, **DO NOT USE SOLVENTS**

ARTICLE FOR DOMESTIC USE AND COMMUNITY USE
Produced, tested and certified in compliance with European Standard EN-581

D aus Polypropylen-Glasfaser mit Anti-UV-Behandlung
KEINER TEMPERATUR AUSSETZEN, die über 50°C oder unter -0°C liegt.
Auf einer ebenen Oberfläche verwenden.
Nur mit Wasser und Seife reinigen,
KEINE LÖSUNGSMITTEL VERWENDEN.

ARTIKEL FÜR DEN PRIVAT UND OBJEKTBEREICH
Hergestellt, getestet und zertifiziert gemäss Europäischer Norm EN-581

E Producto de polipropileno fibra de vidrio con tratamiento anti UV
NO EXPONGA a + 50°C y - 0°
Use sobre una superficie plana.
Limpie con agua y jabón, **NO USE SOLVENTES**

ARTÍCULO PARA USO DOMÉSTICO Y COLECTIVIDADES
Producto, probado y certificado según la norma europea en-581

PT Produto de fibra de vidro de polipropileno com tratamento anti UV
NÃO EXPOR a + 50°C e - 0°
Usar sobre uma superfície plana.
Limpar com água e sabão, **NÃO USAR SOLVENTES**

ARTIGO PARA USO DOMÉSTICO E CONTRACT
Producto, testado e certificado de acordo com a norma europeia en-581



- Pulire con acqua e detersivo liquido o cremoso evitando prodotti abrasivi. Risciacquare bene e asciugare.
- Nettoyer avec de l'eau et un détergent liquide ou crémeux en évitant les produits abrasifs. Bien rincer et sécher.
- Clean with water and liquid or creamy detergent avoiding abrasive products. Rinse well and dry.
- Mit Wasser und flüssigem oder cremigem Reinigungsmittel reinigen. Scheuermittel vermeiden. Gut abspülen und trocknen.
- Limpiar con agua y detergente líquido o cremoso evitando productos abrasivos. Enjuague bien y seque.
- Limpe com água e detergente líquido ou cremoso evitando produtos abrasivos. Enxágüe bem e ary.



ATTENZIONE

Lavare le federe soltanto a mano ed in acqua fredda. Cuscini con tessuto idrorepellente, si consiglia in caso di pioggia e/o umidità prolungata di rimuoverli e posizionarli all'asciutto.

ATTENTION

Laver les housses à la main et à l'eau froide seulement. Coussins avec tissu imperméable. Il est recommandé de retirer les coussins en cas de pluie et/ou humidité prolongées et de les conserver dans un endroit sec.

ATTENTION

Hand wash the covers with cold water only. Cushions with waterproof fabric. It is recommended to remove the cushions in case of prolonged rain and/or humidity and put them in a dry place.

ACHTUNG

Kissenbezüge nur von Hand in kaltem Wasser waschen. Kissen Wasserdicht gestaltet. Es wird empfohlen, die Kissen bei längerem Regen und/oder Feuchtigkeit zu entfernen und an einem trockenen Ort positionieren.

ATENCIÓN

Lavar las fundas a mano en agua fría. Cojines con tejido impermeable. Se recomienda quitar los cojines en caso de lluvia y/o humedad prolongada y guardarlos en un lugar seco.

ATENÇÃO

Lavar as capas das almofadas à mão em água fria. Almofadas com tecido impermeável. Recomenda-se retirar as almofadas em caso de chuva e/ou umidade prolongada e mantê-las em local seco.

Elenco Componenti

LISTE DES COMPOSANTS
COMPONENT LIST
KOMPONENTENLISTE
LISTA DE COMPONENTES
LISTA DE COMPONENTES

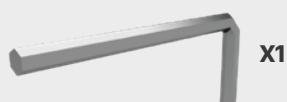
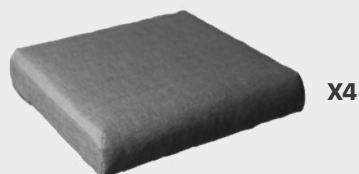
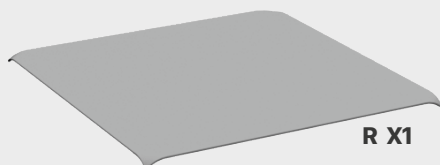
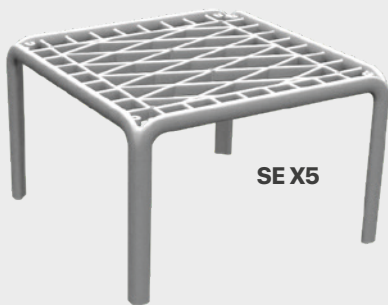
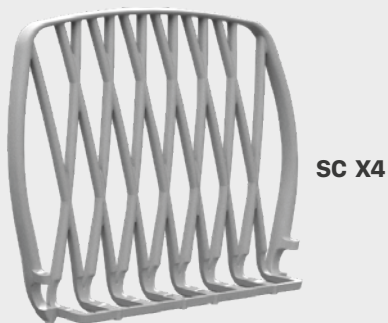
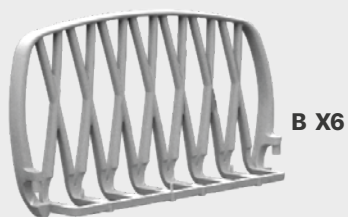

Montaggio Tavolino

1

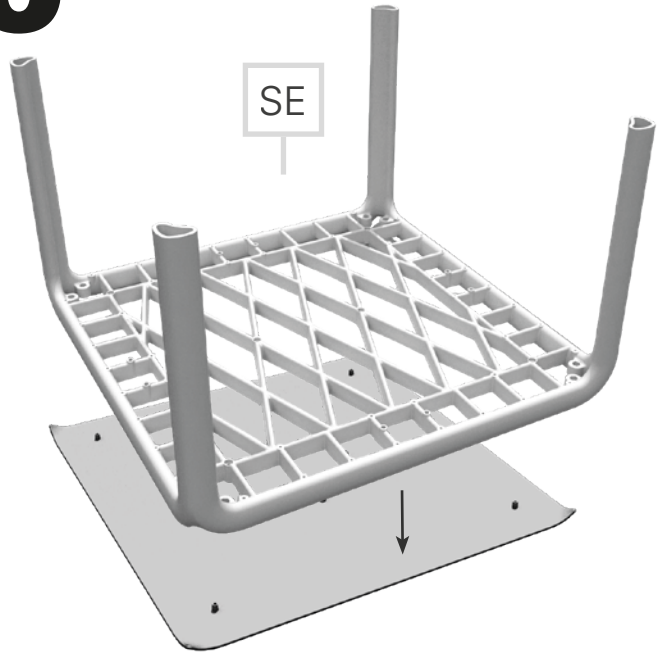
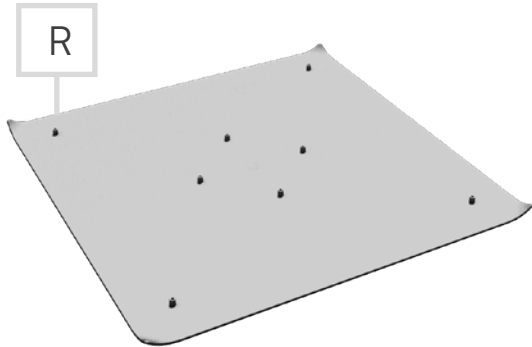

2

x6

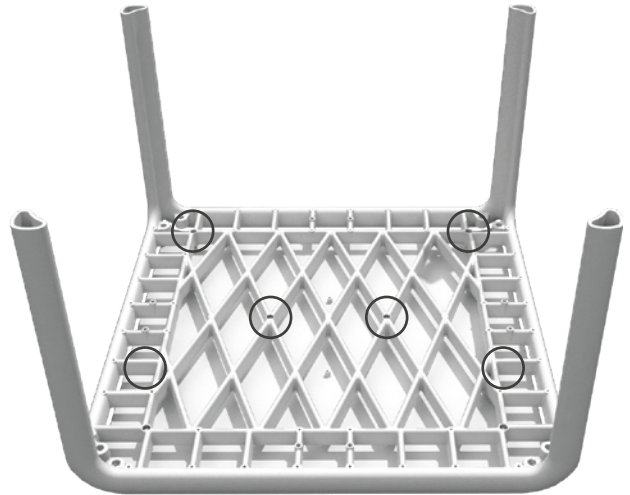
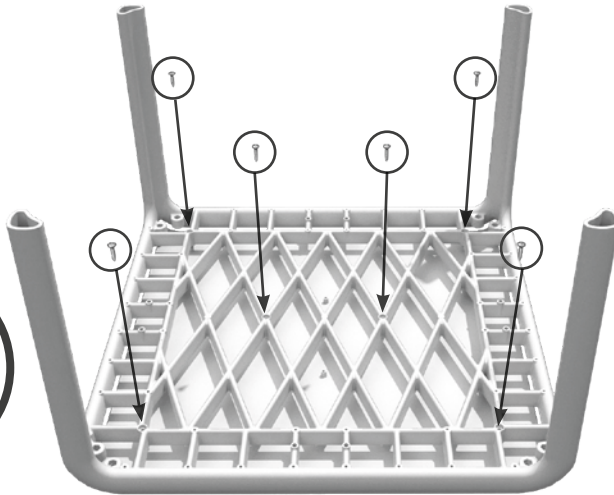

3

PSx4

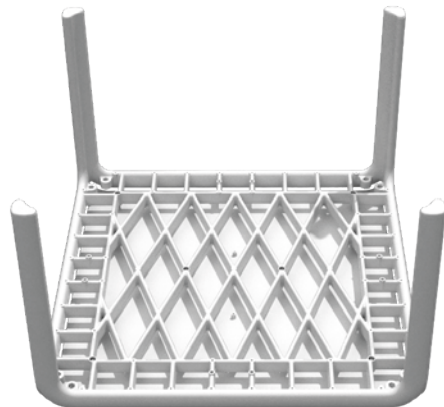
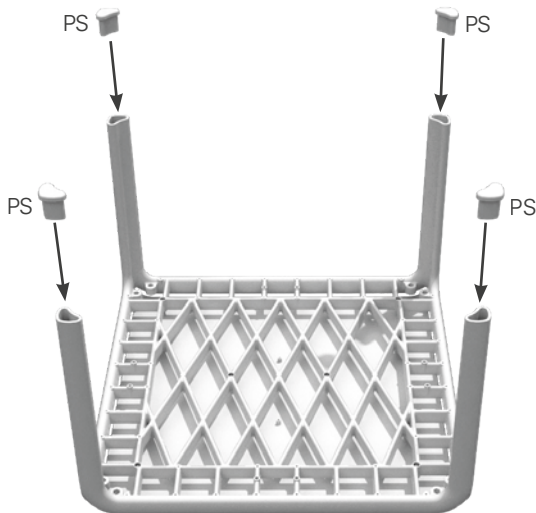

Montaggio Poltrona

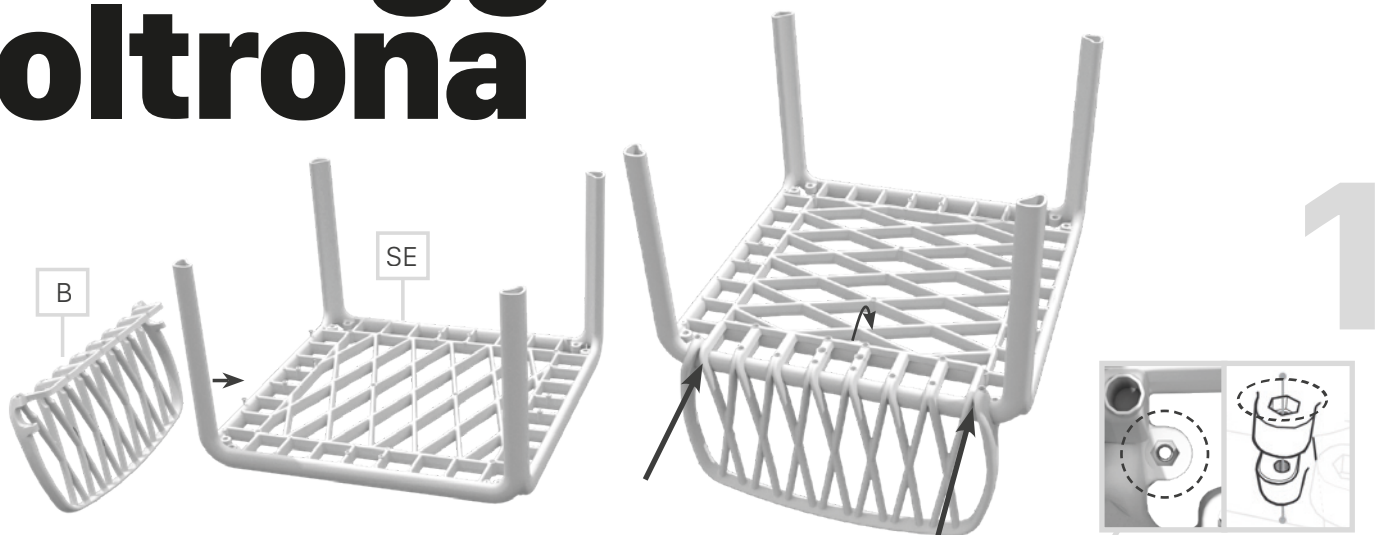

!!!

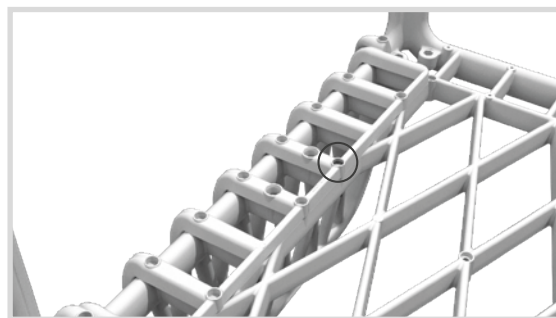
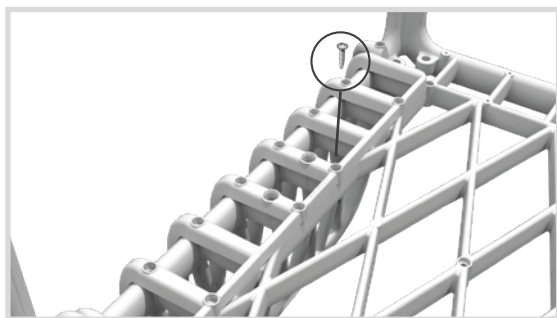
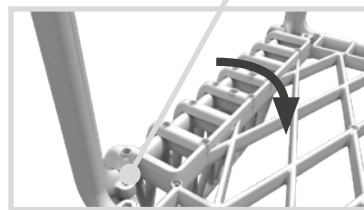
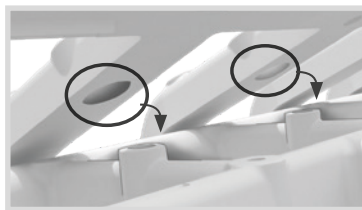
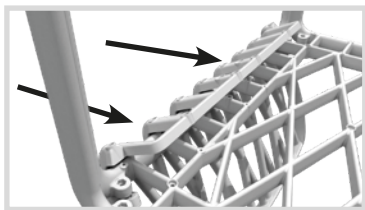

2

x1

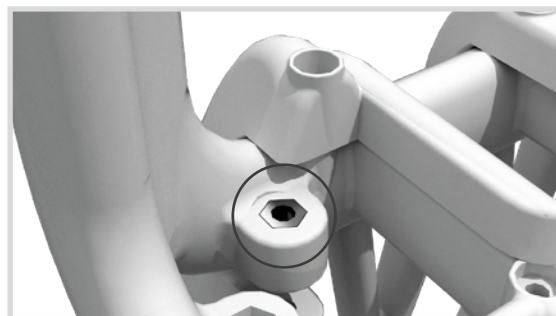
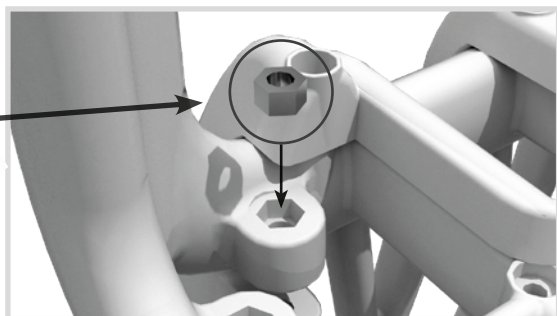

3

x2

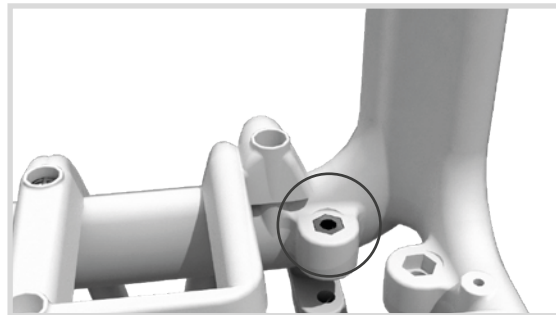
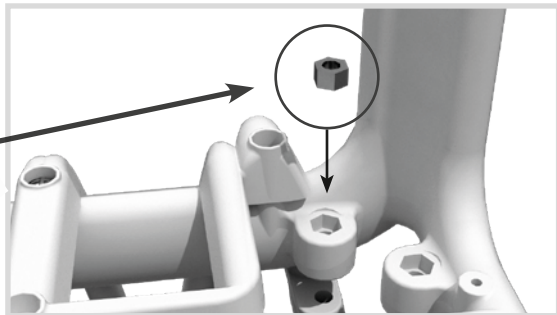

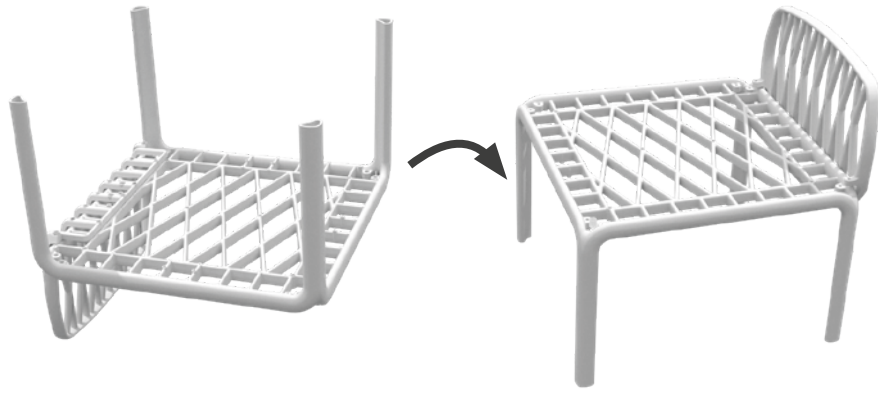

4

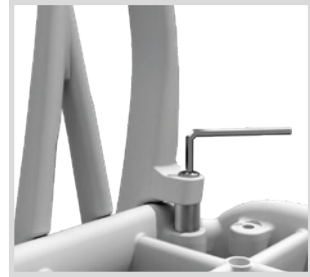
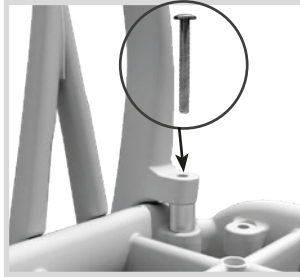
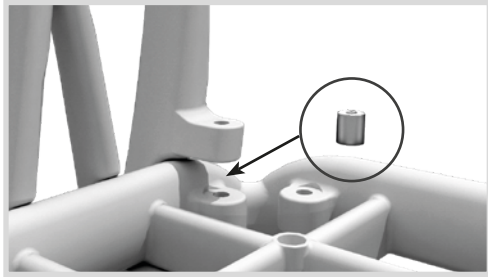
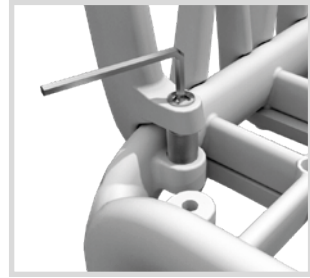
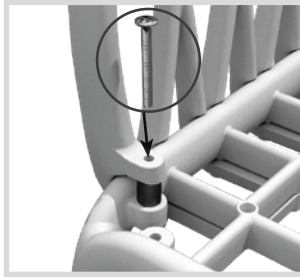
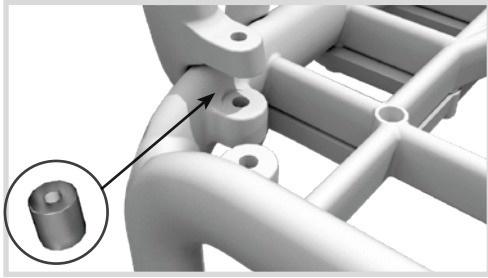

5

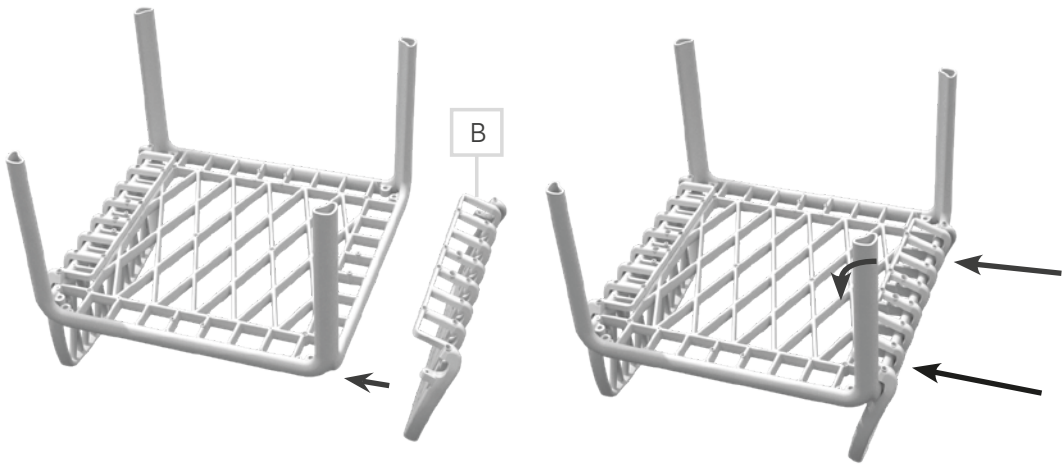

!!!

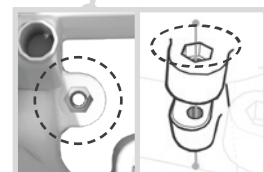
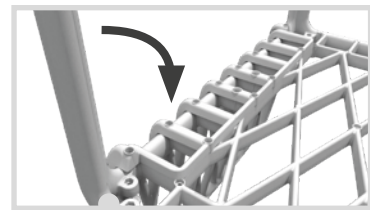
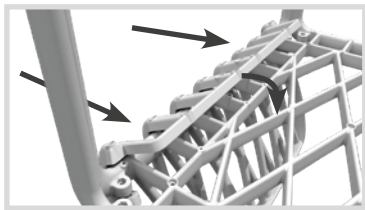

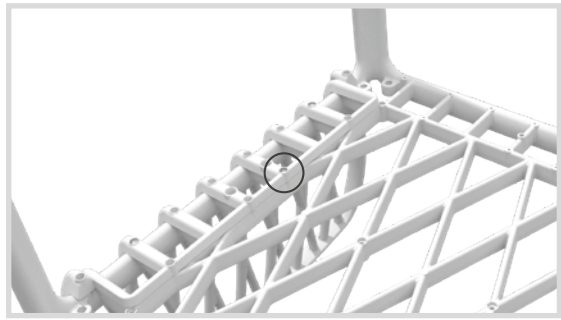
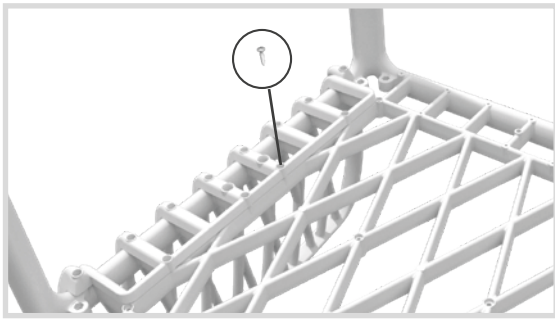

6

 x1

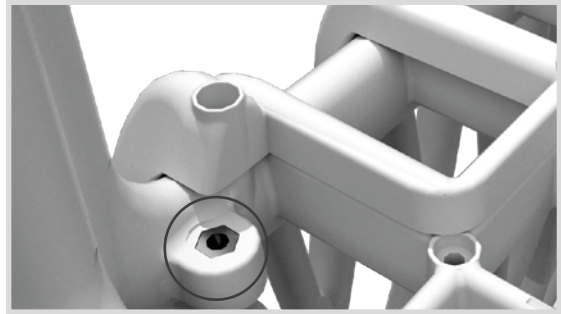
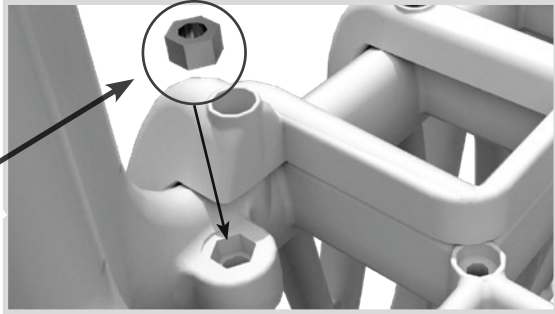

7

 x2

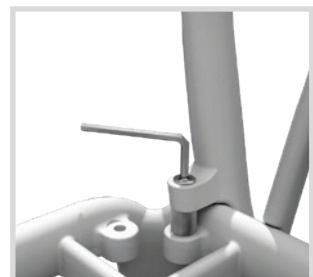
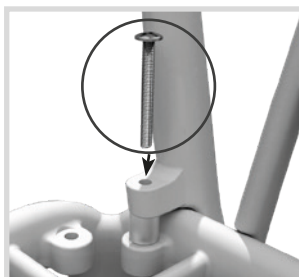
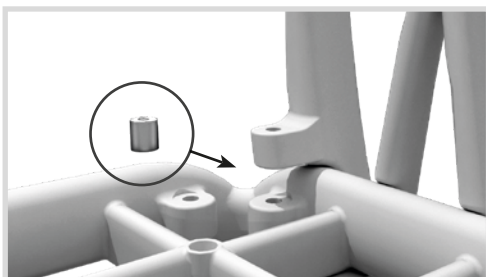
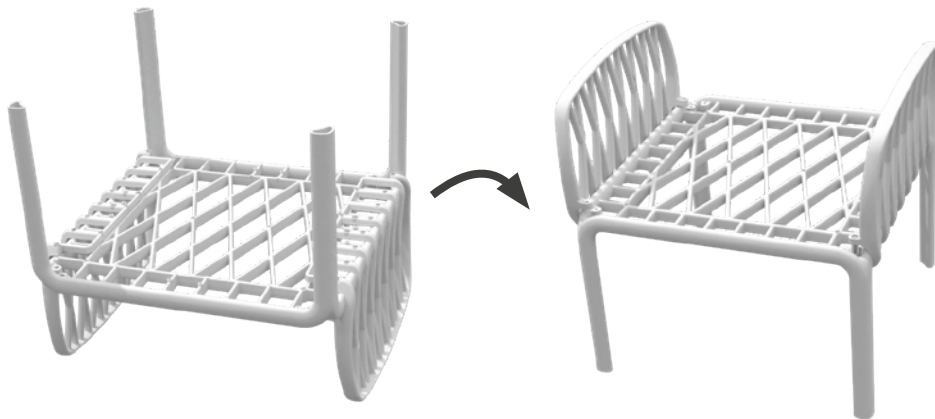
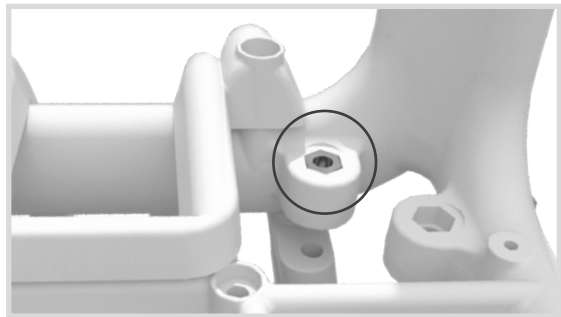
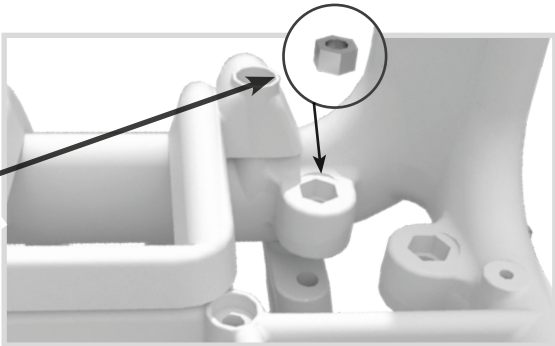

8

 x2

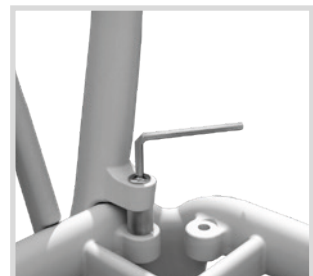
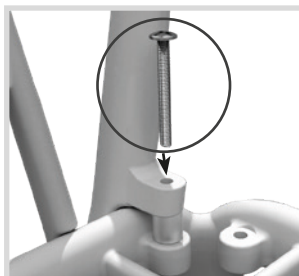
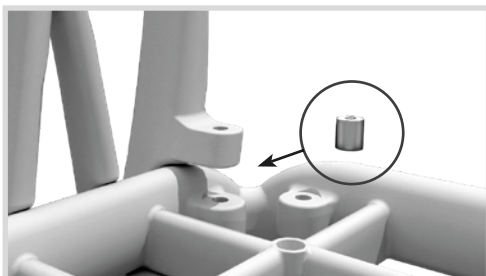

 x2



9

SC

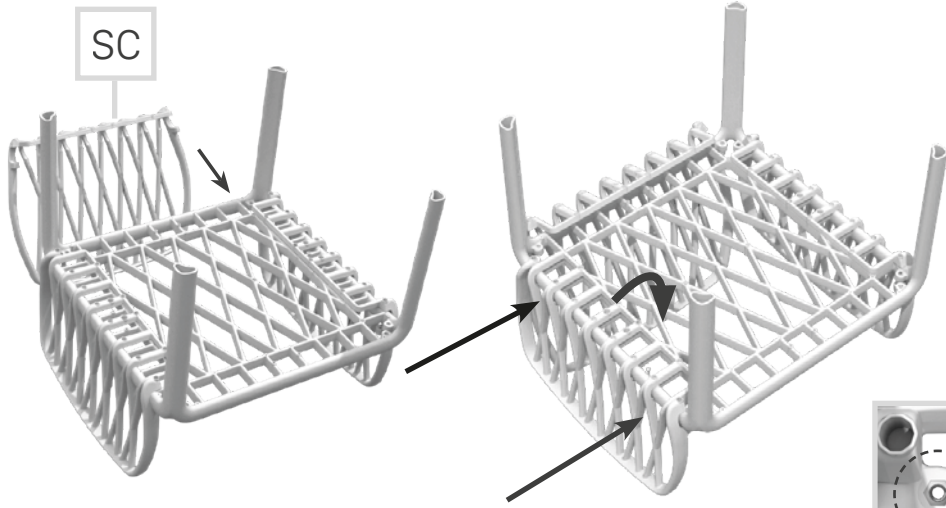

!!!

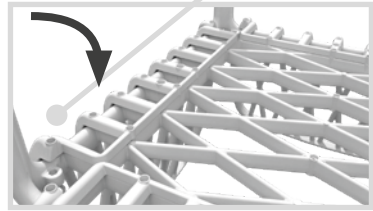
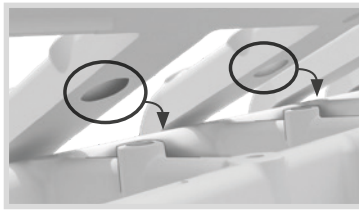
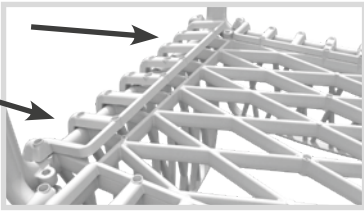

10

x1

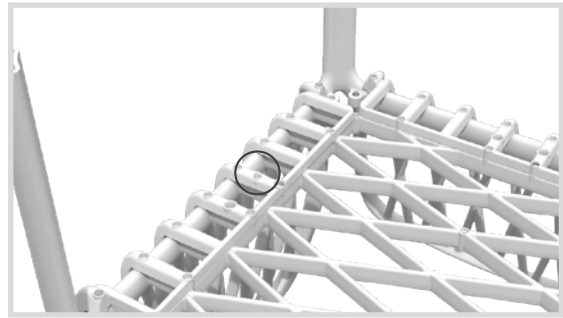
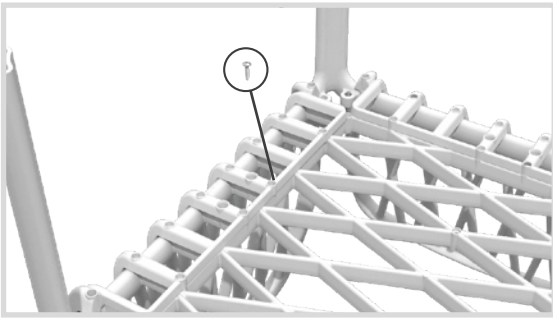

11

x2

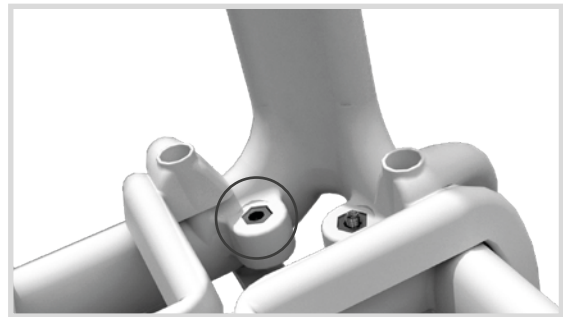
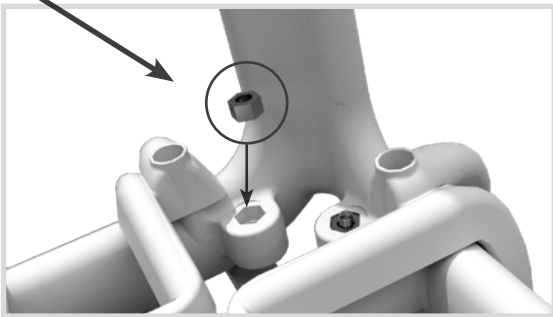
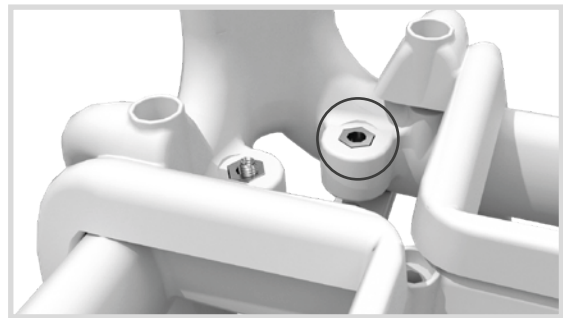
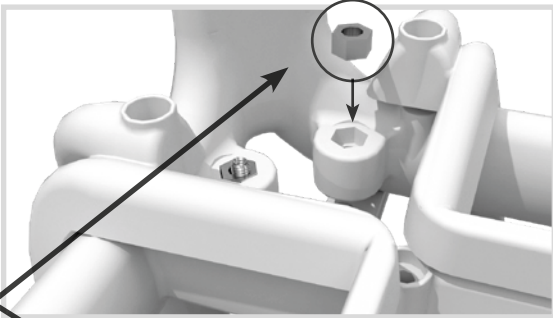

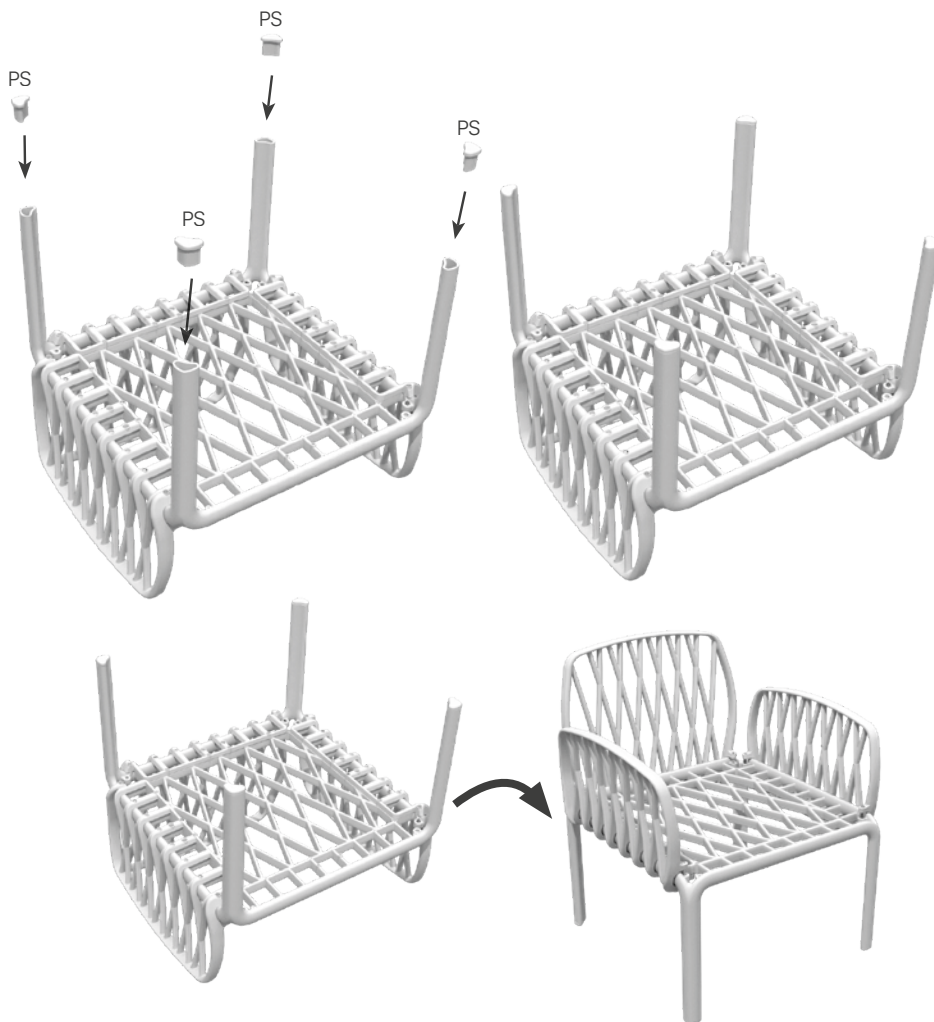

12

PSx4

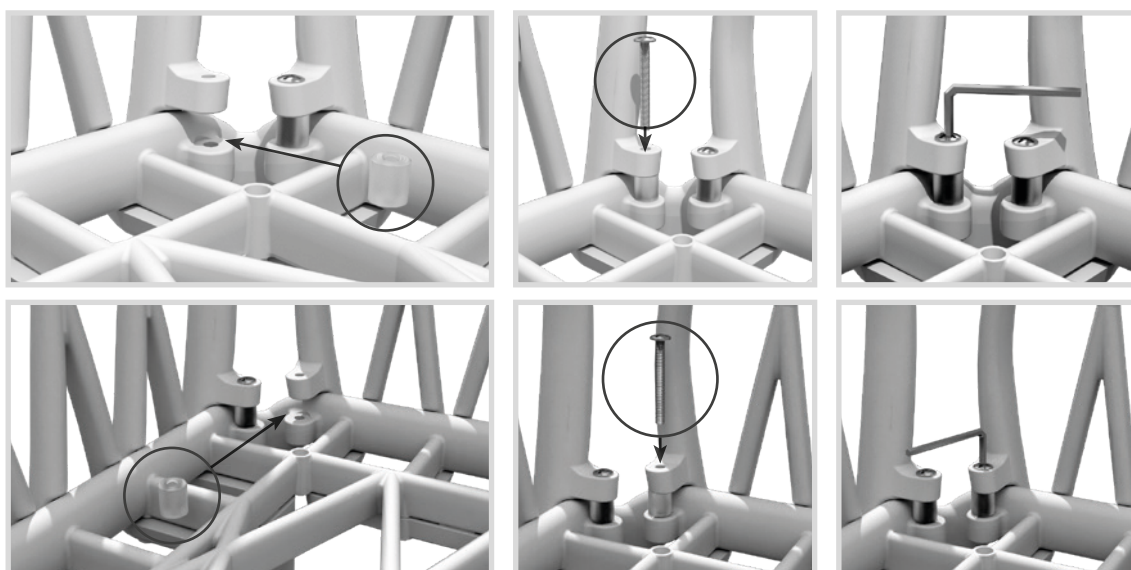

13

PS x2

Screw x2

Allen key



Montaggio Divano



BRACCIOLO SINISTRO (DA SEDUTO)
ACCOUDOIR GAUCHE (ASSIS)
LEFT ARMREST (SITTING)
LINKE ARMLEHNE (SITZEND)
REPOSABRAZOS IZQUIERDO (SENTADO)
BRAÇO ESQUERDO (SENTADO)

1

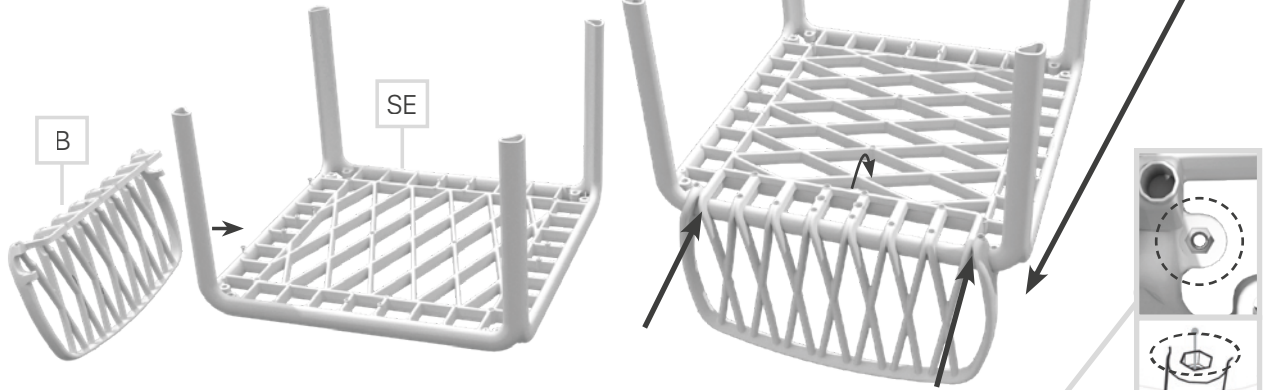

!!!

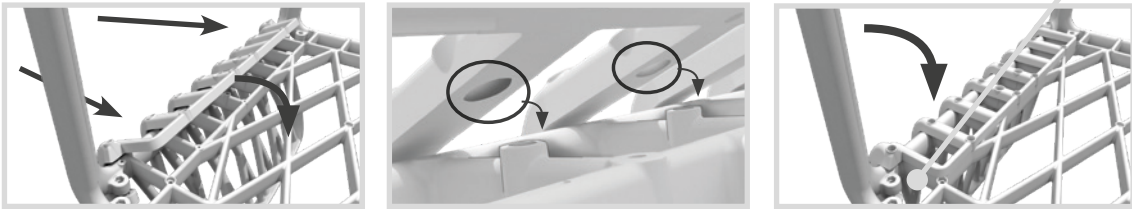

2

x1

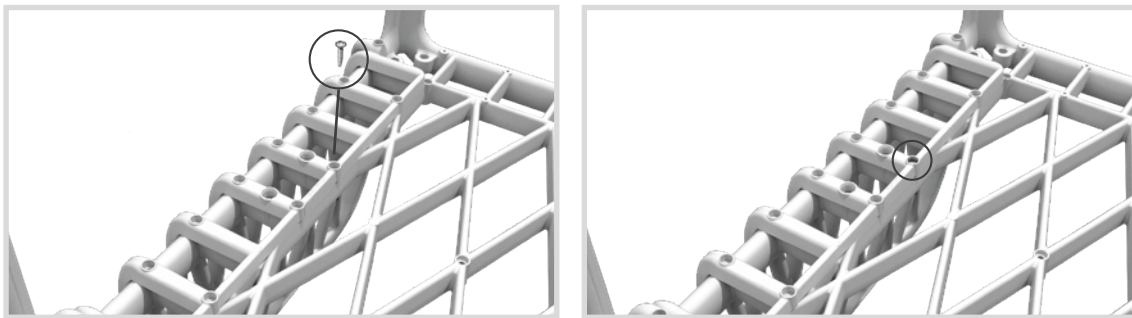

3

x2

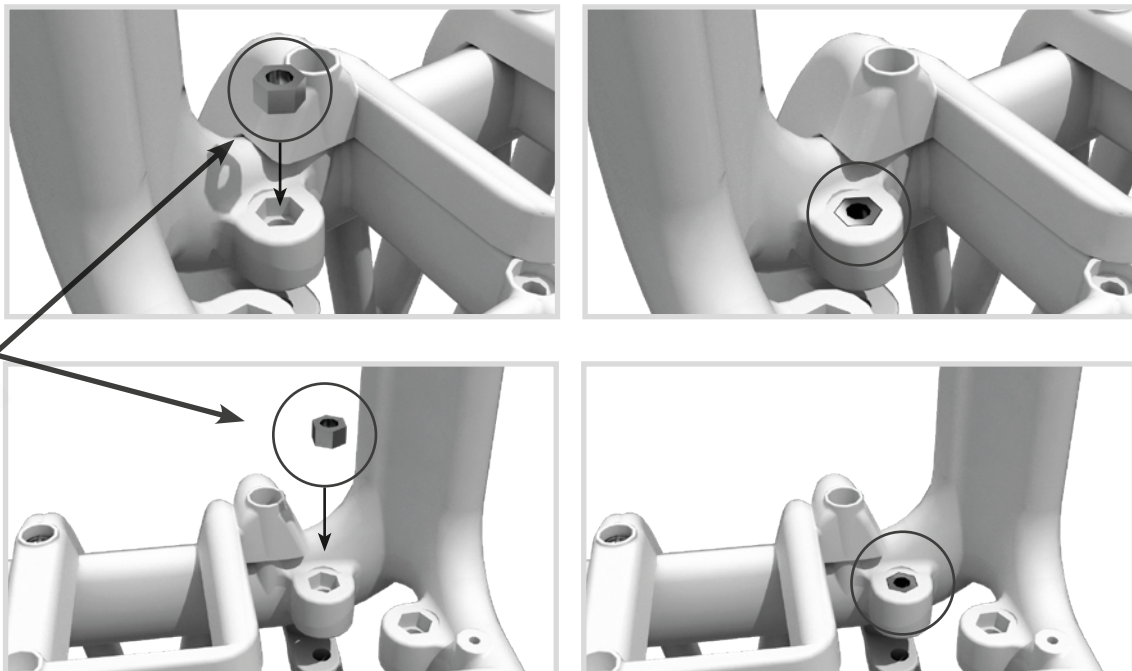

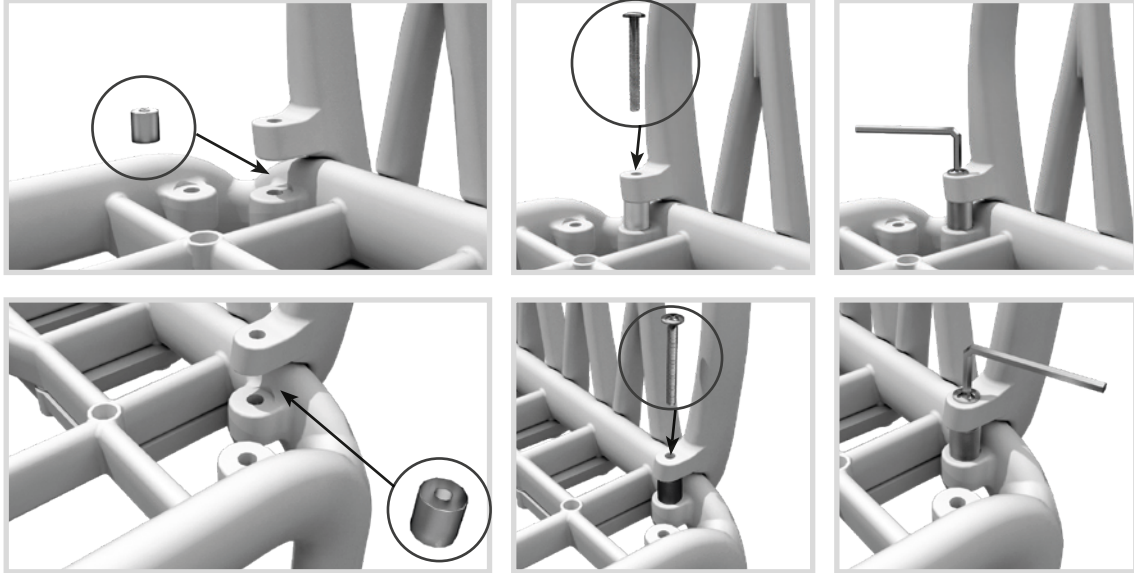
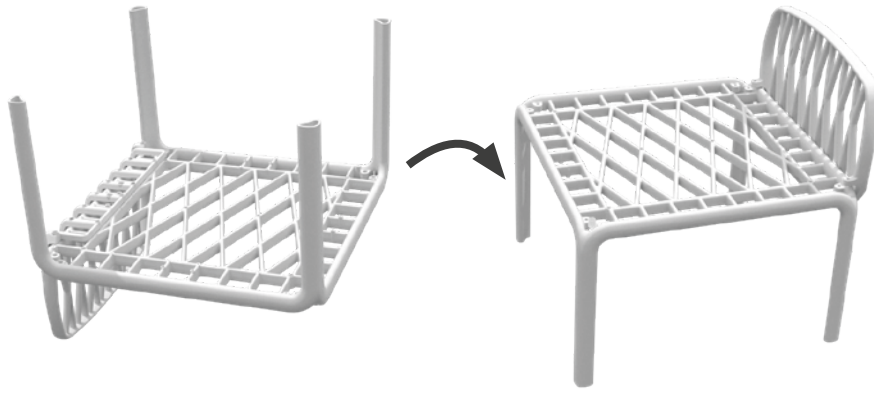

4

 x2

 x2

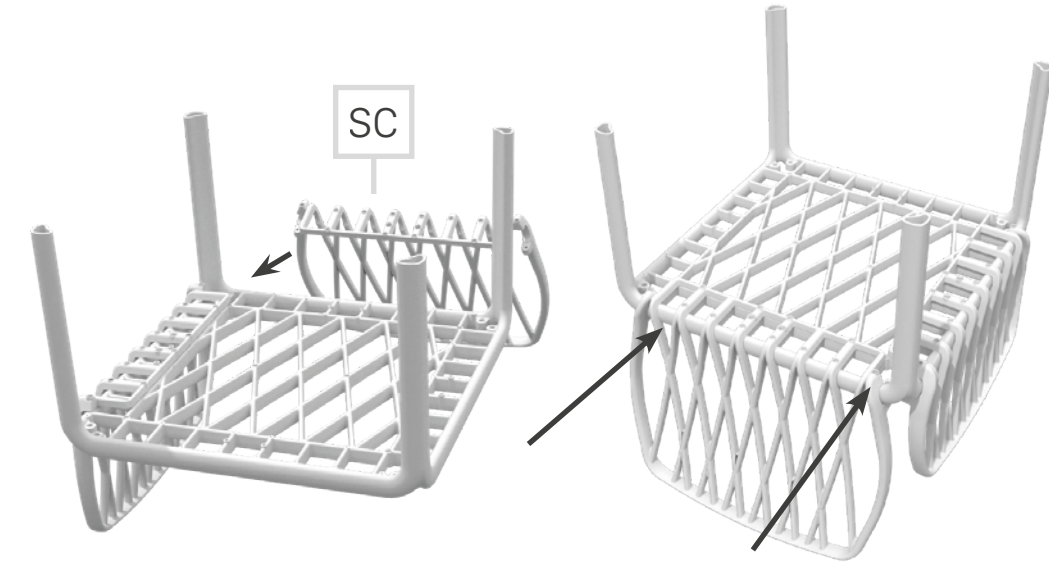

5

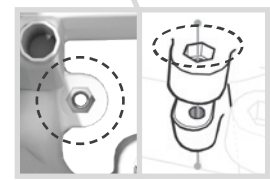

6

⚪ x1

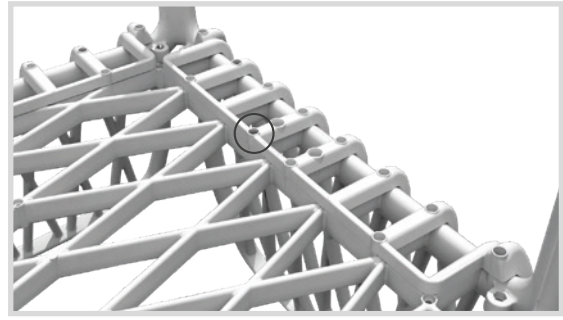
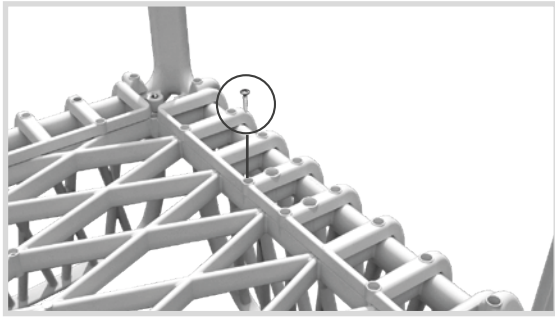

7

⚪ x2

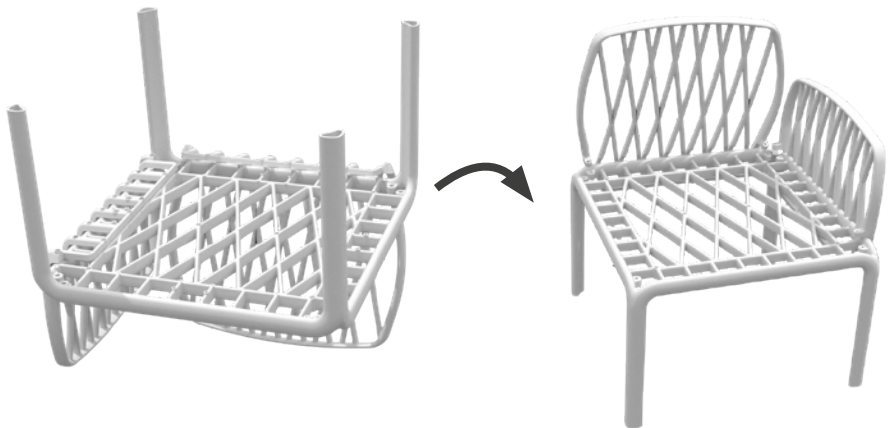
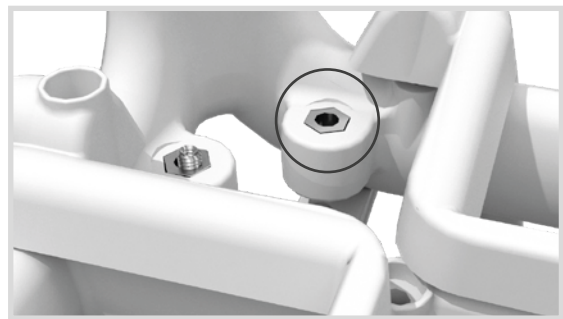
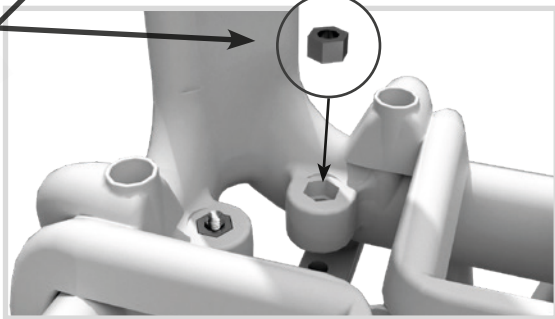
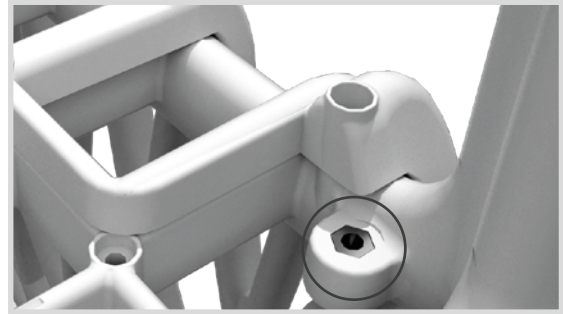
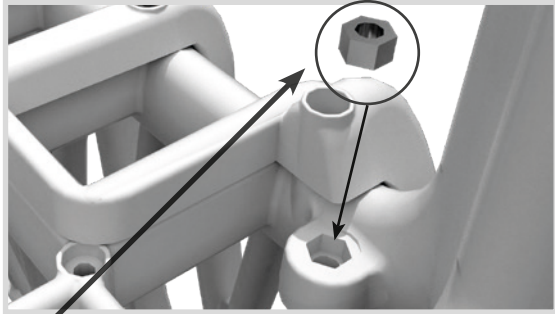

8

⚪ x2

⚪ x2

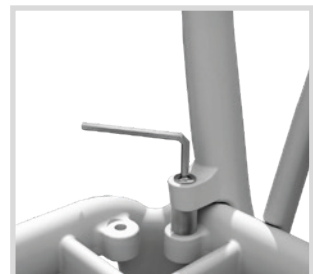
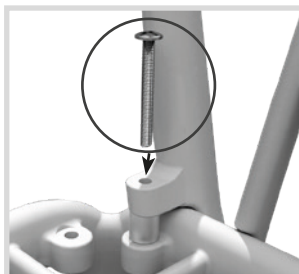
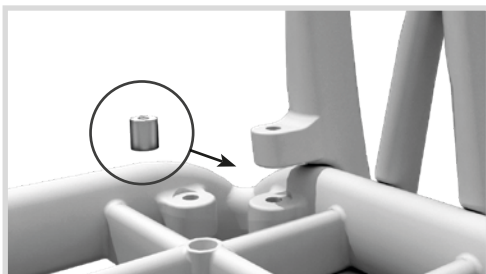
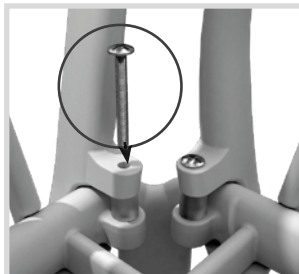
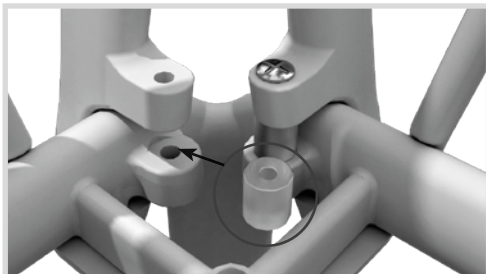



BRACCIOLLO DESTRO (DA SEDUTO)
ACCOUDOIR DROIT (ASSIS)
RIGHT ARMREST (SITTING)
RECHTE ARMLEHNE (SITZEND)
REPOSABRAZOS DERECHO (SENTADO)
BRAÇO DIREITO (SENTADO)

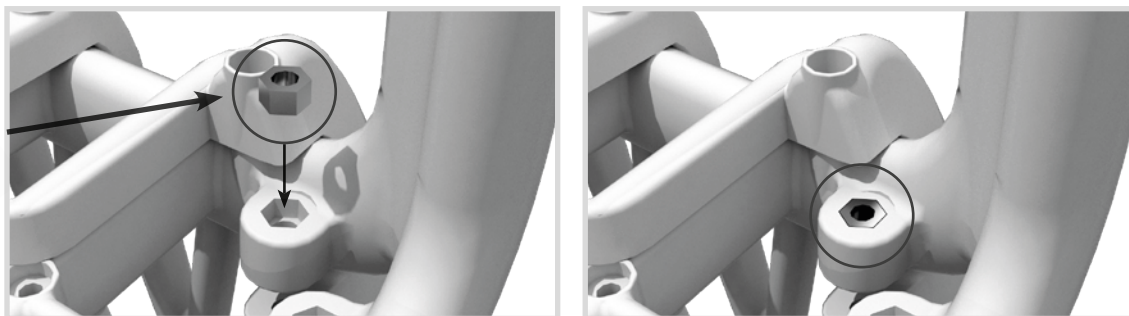
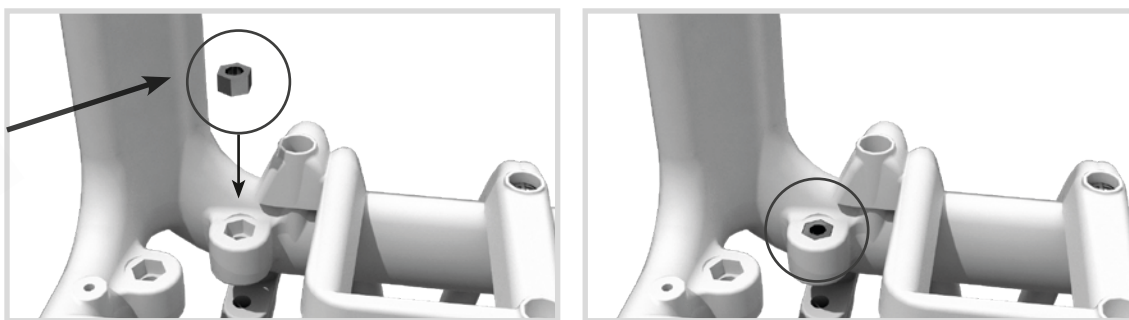
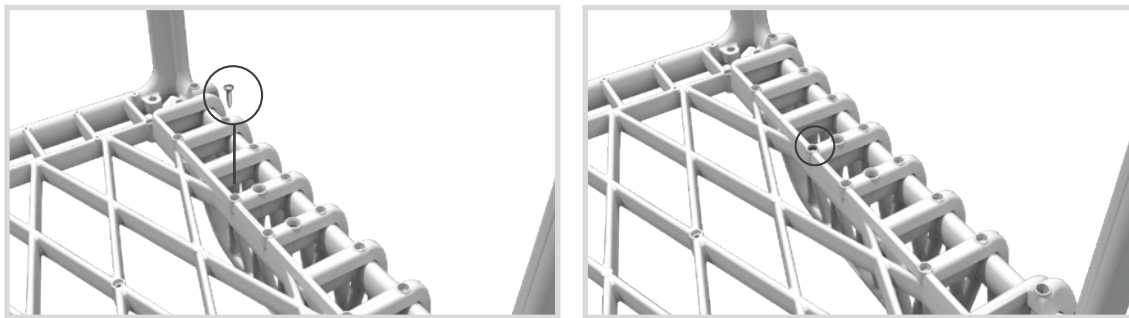
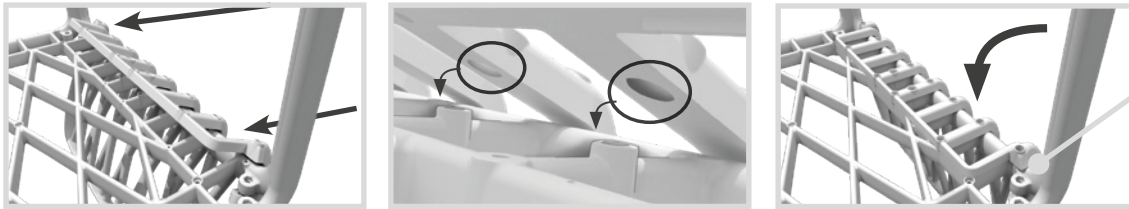
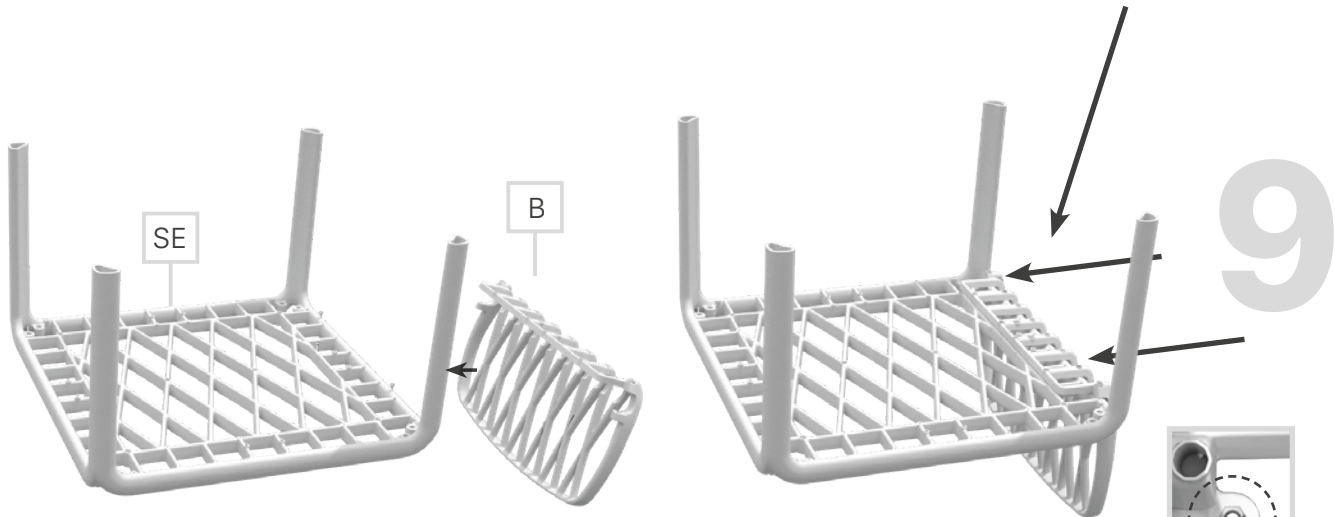

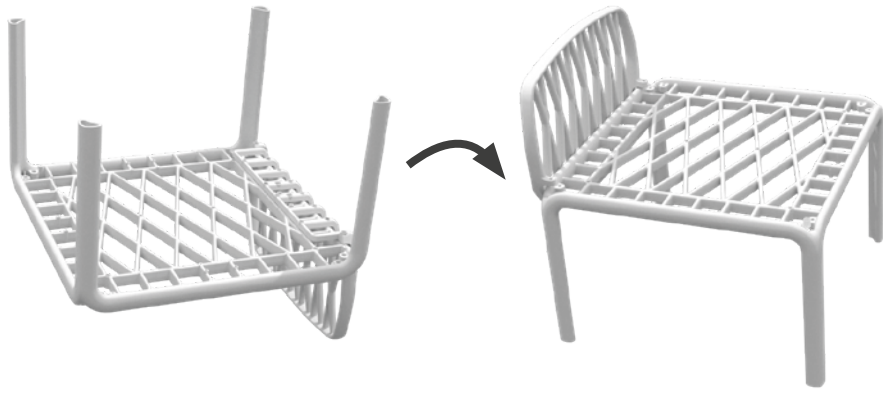

12

 x2

 x2



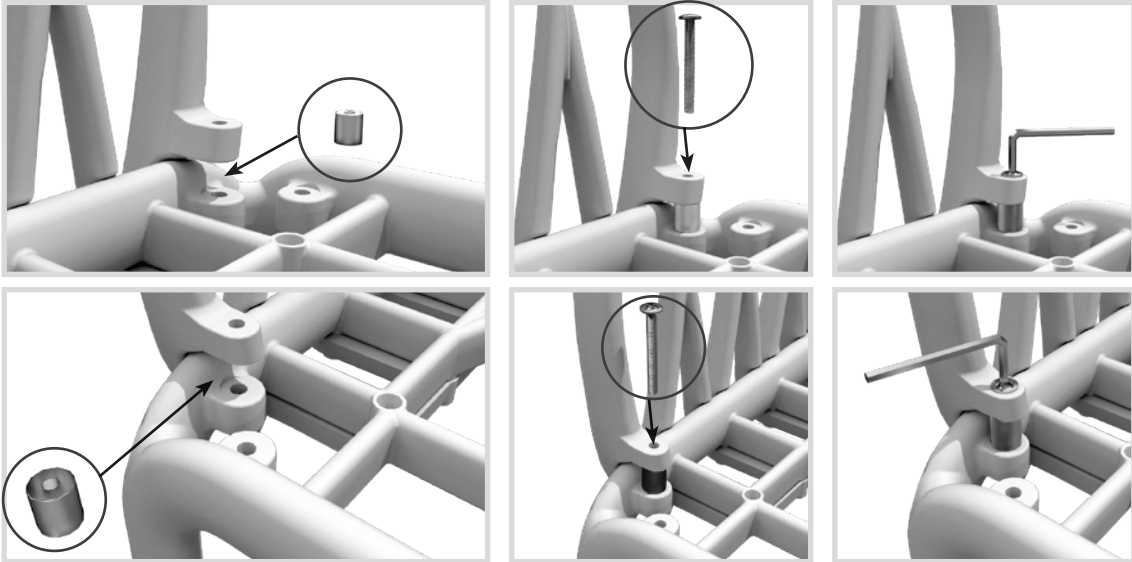

13

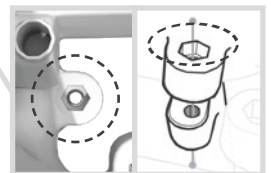
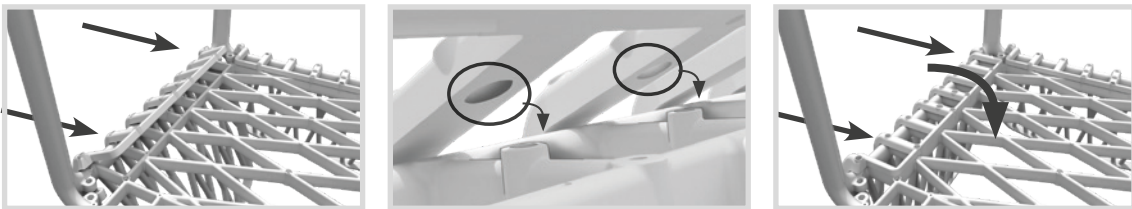
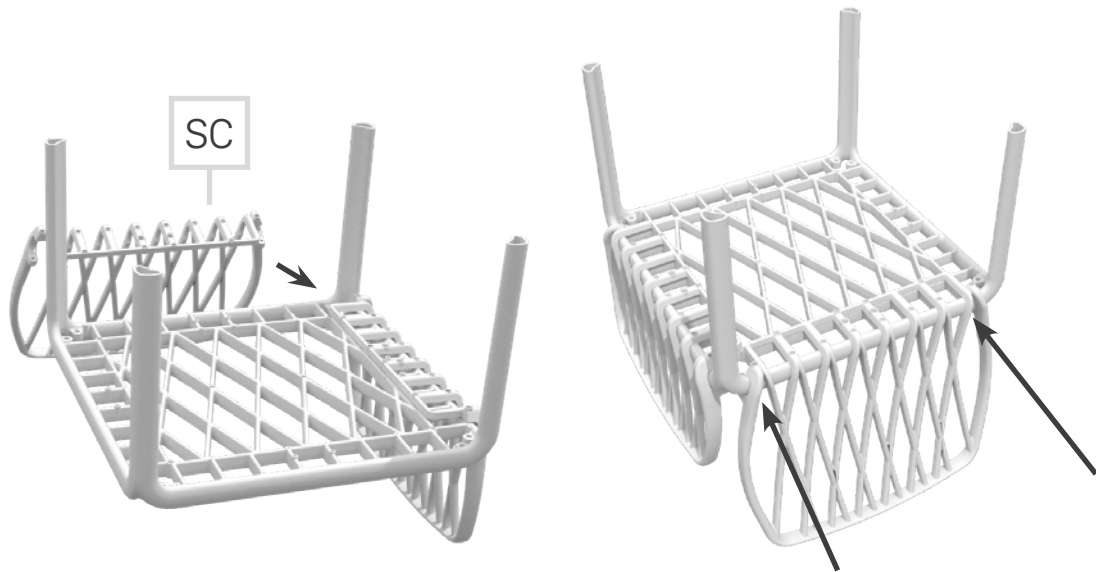

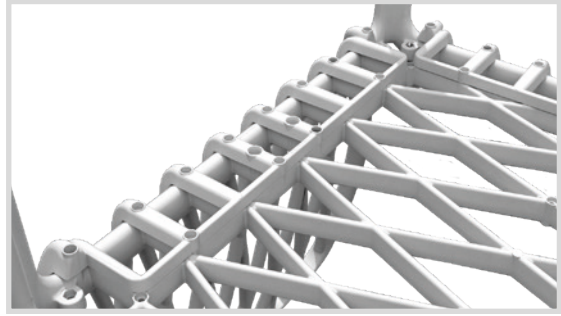
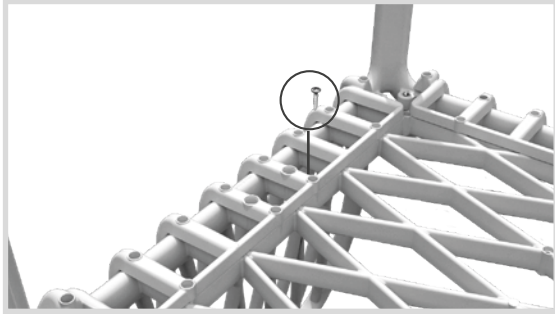

14

 x1

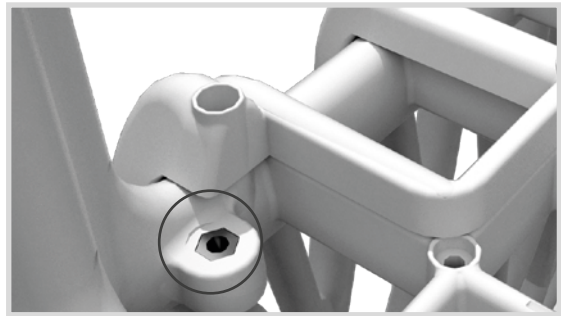
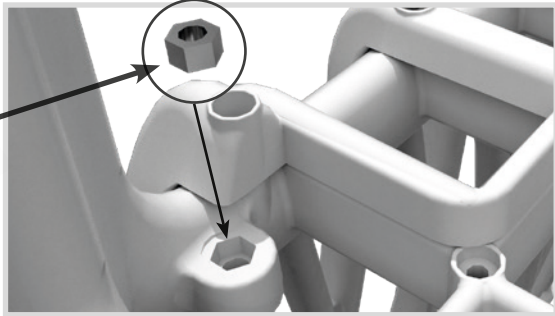

15

 x2

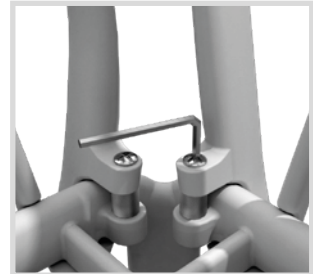
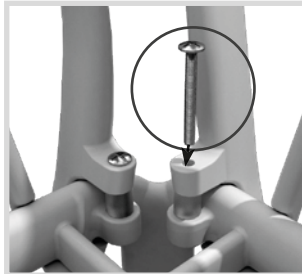
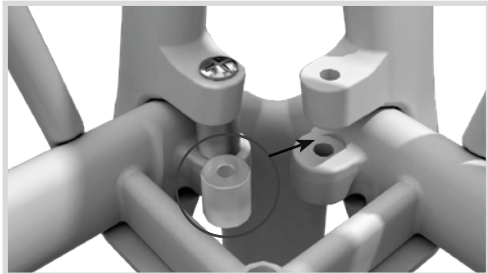
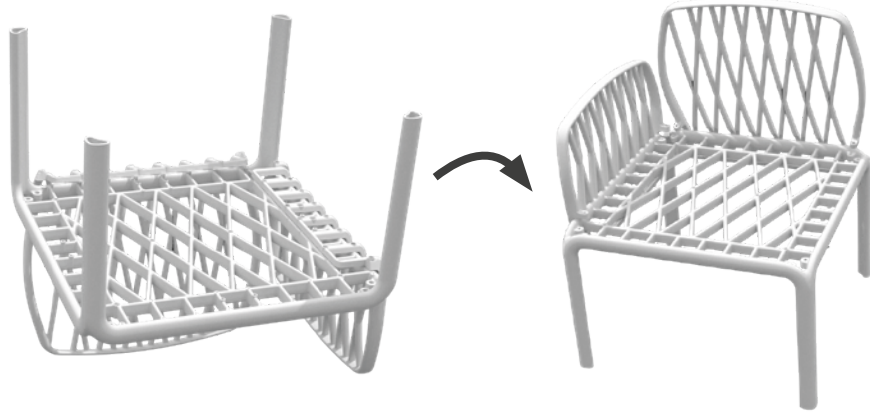
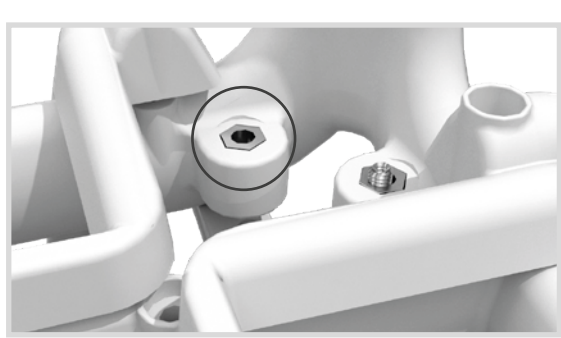
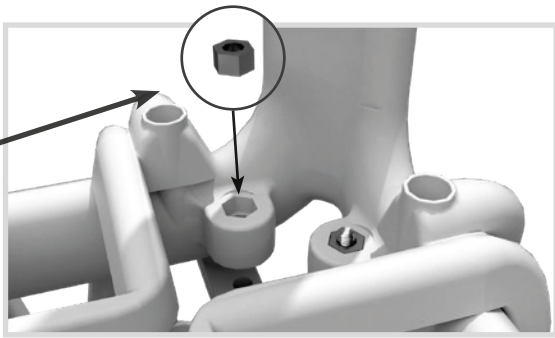

16

 x2

 x2

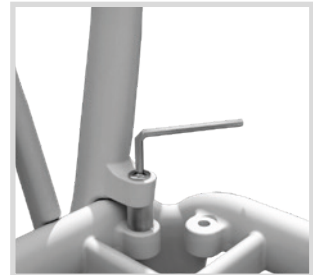
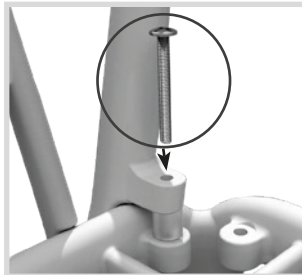
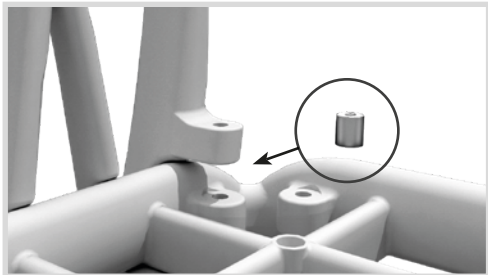

17



18

Mx2

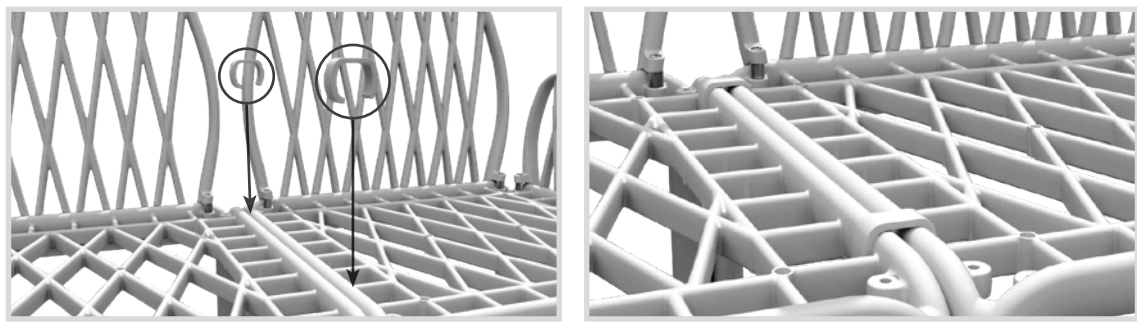

19

PSx4

PDx2

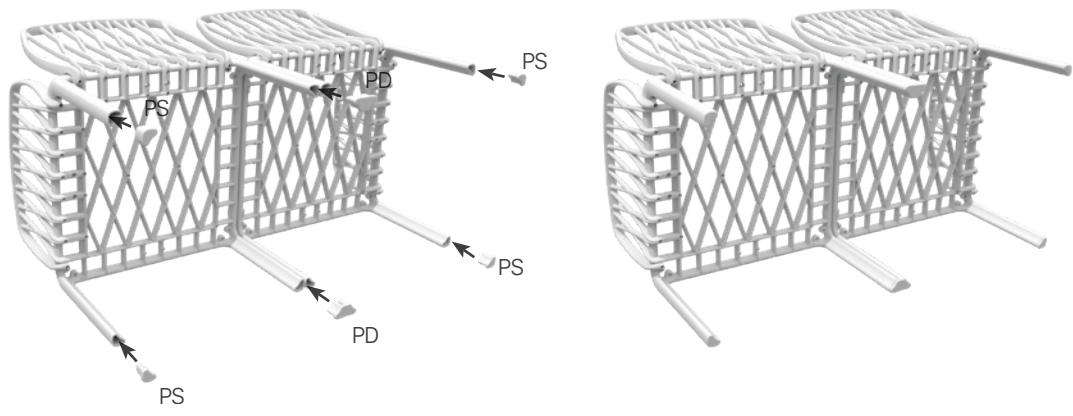

20

x3

x6

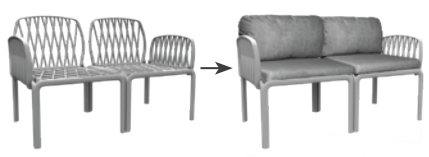
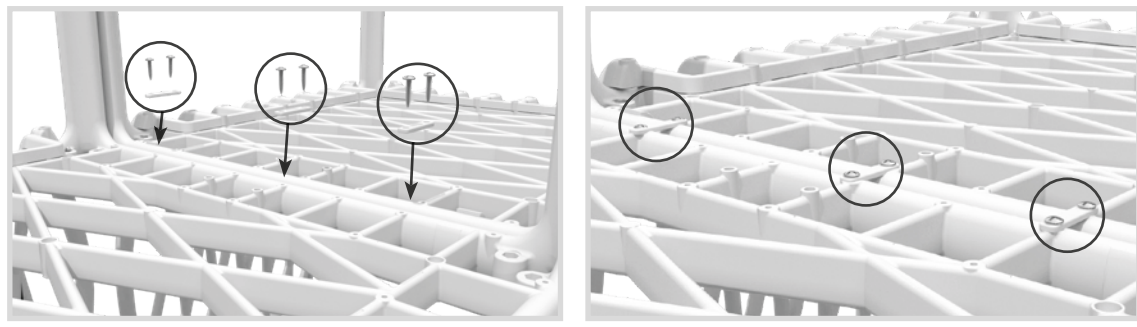

MODULARITÀ ALTERNATIVA // MODULARITÉ ALTERNATIVE // ALTERNATIVE MODULARITY // ALTERNATIVE MODULARITÄT // MODULARIDADE ALTERNATIVA

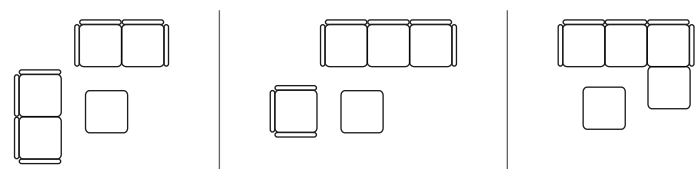

Scansiona per vedere tutte le varianti disponibili.
Scan to see all available variants.